

F710 – sand separator 3/4” – thread

Article number: 482.700.710
Net weight: 6 kg.
Flow Rate: 3 m³/h.
Max. working pressure: 8 bar; 116 psi.
Connection: 3/4” - thread.

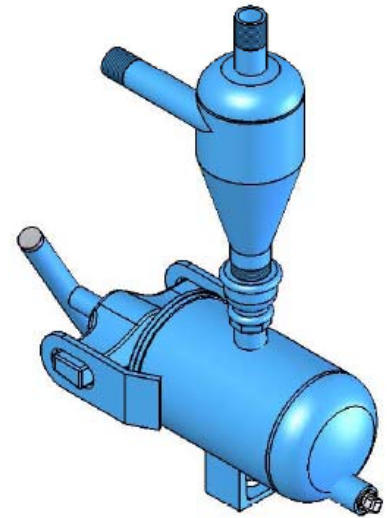

Article No.	Description
482.710.001	Upper gasket
482.710.011	Cover
482.710.021	T-handle
482.710.031	Shutter unit
482.710.041	Steel insert
482.710.051	1.5 liter chamber

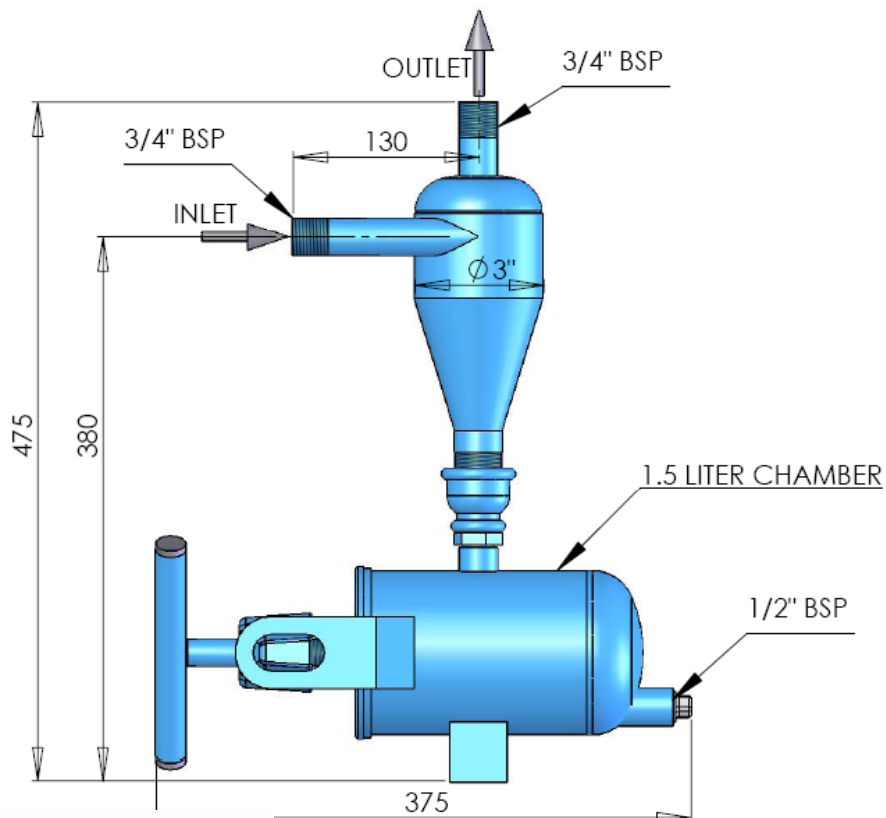

Power Filter



**POWER
 PLASTICS b.v.**

More info - - Call +31 252 216650

F720 – sand separator 1.0” – thread

Article number: 482.700.720
Net weight: 9 kg.
Flow Rate: 5 m³/h.
Max. working pressure: 8 bar; 116 psi.
Connection: 1.0” - thread.

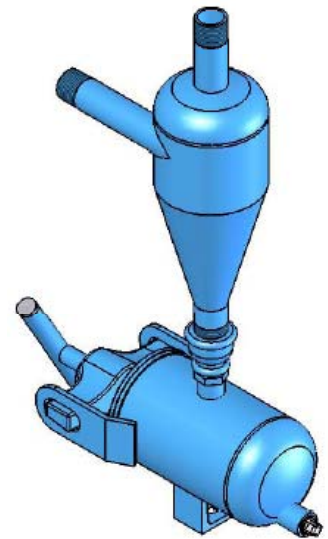

Article No.	Description
482.710.001	Upper gasket
482.710.011	Cover
482.710.021	T-handle
482.710.031	Shutter unit
482.710.041	Steel insert
482.710.051	1.5 liter chamber

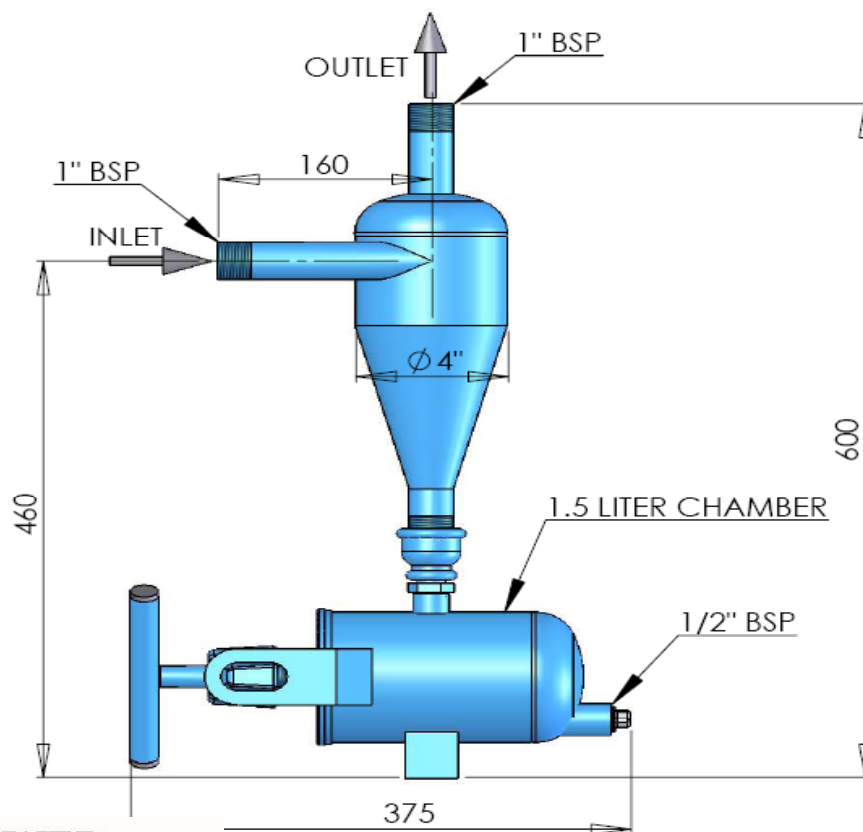

Power Filter



**POWER
 PLASTICS b.v.**

More info - - Call +31 252 216650

F730 – sand separator 1.5” – thread

Article number: 482.700.730
Net weight: 9 kg.
Flow Rate: 11 m³/h.
Max. working pressure: 8 bar; 116 psi.
Connection: 1.5” - thread.

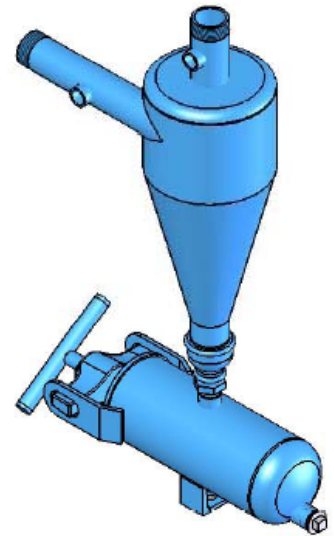

Article No.	Description
482.710.001	Upper gasket
482.710.011	Cover
482.710.021	T-handle
482.710.031	Shutter unit
482.710.042	Steel insert
482.710.052	2,5 liter chamber

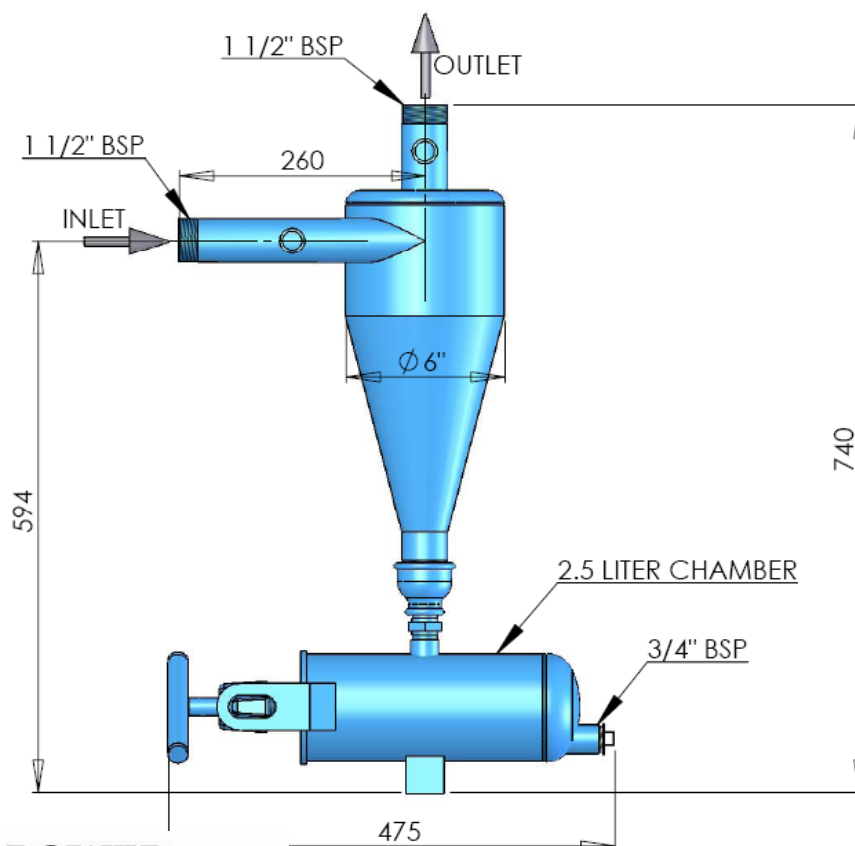

**POWER
PLASTICS b.v.**

More info - - Call +31 252 216650

Power Filter

F740 – sand separator 2.0” – thread

Article number: 482.700.740
Net weight: 15 kg.
Flow Rate: 15 m³/h.
Max. working pressure: 8 bar; 116 psi.
Connection: 2.0” - thread.

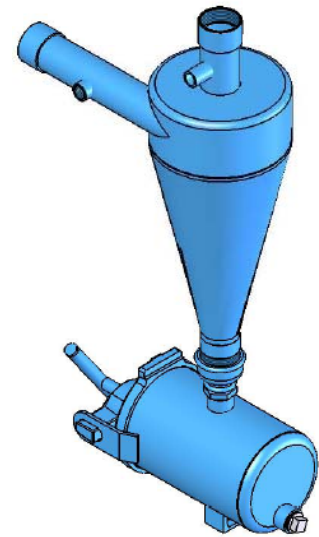

Article No.	Description
482.710.002	Upper gasket
482.710.012	Cover
482.710.022	T-handle
482.710.032	Shutter unit
482.710.043	Steel insert
482.710.053	5.0 liter chamber

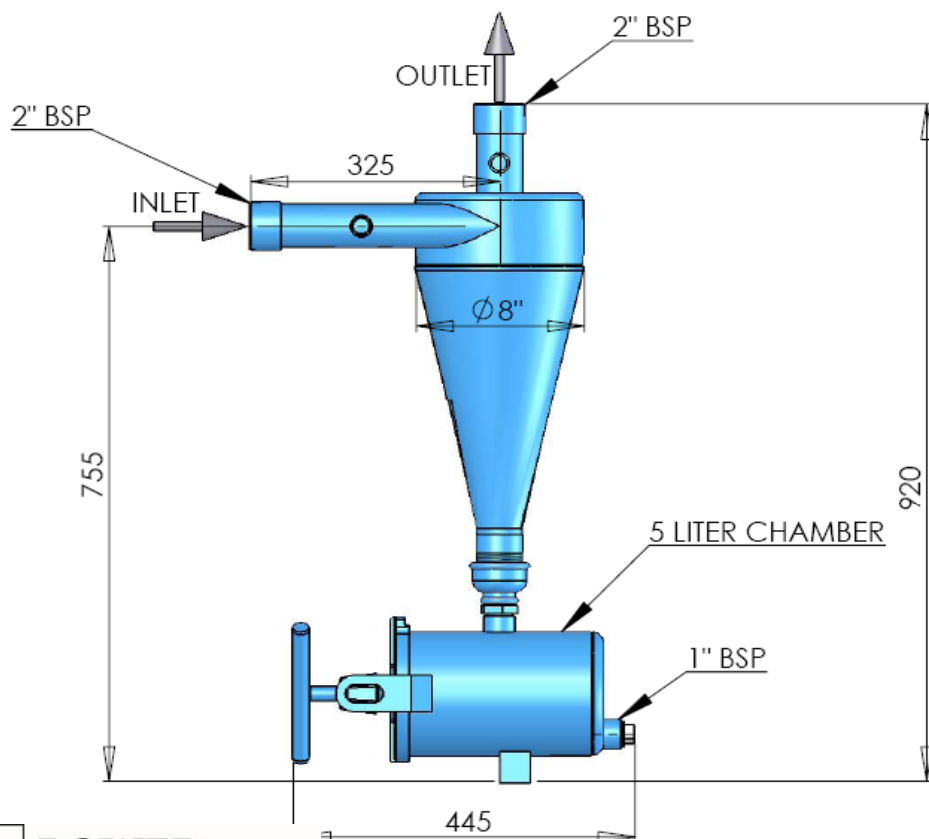

Power Filter



**POWER
 PLASTICS b.v.**

More info - - Call +31 252 216650

F750 – sand separator 3.0” – flange

Article number: 482.700.750
Net weight: 21 kg.
Flow Rate: 30 m³/h.
Max. working pressure: 8 bar; 116 psi.
Connection: 90mm - flange.

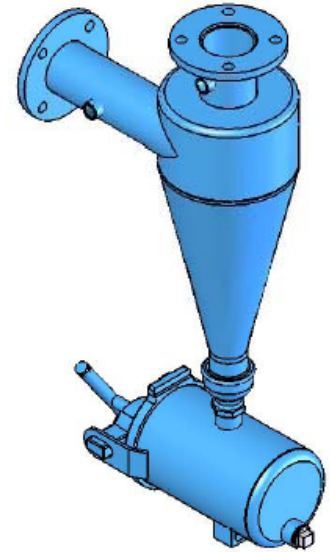

Article No.	Description
482.710.002	Upper gasket
482.710.012	Cover
482.710.022	T-handle
482.710.032	Shutter unit
482.710.043	Steel insert
482.710.053	5.0 liter chamber

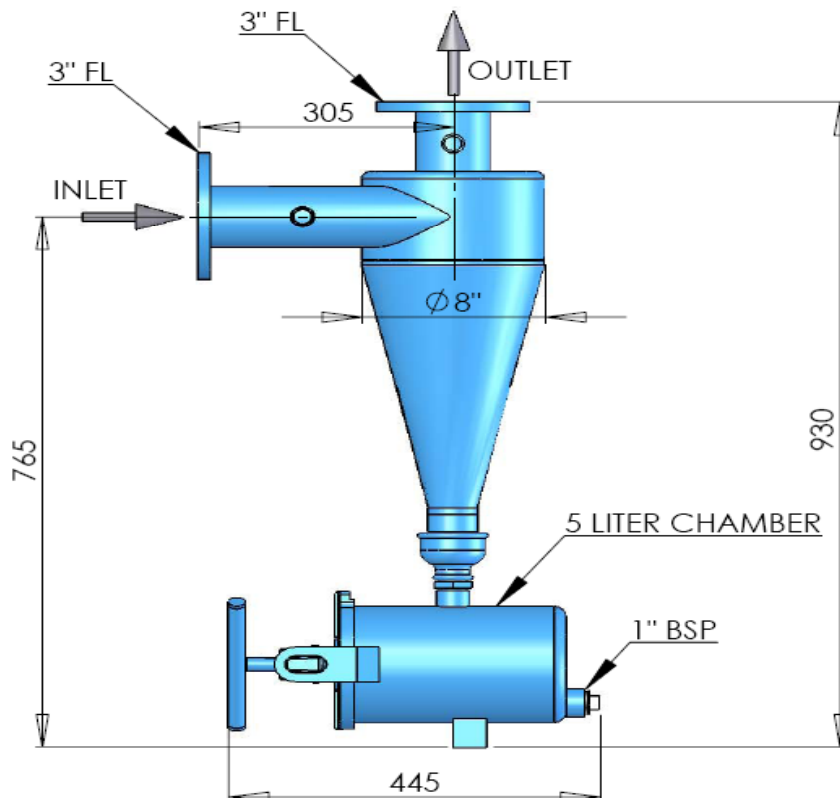

Power Filter



**POWER
PLASTICS b.v.**

More info - - Call +31 252 216650

F755 – sand separator 3.0”x4.0” – flange

Article number: 482.700.755
Net weight: 70 kg.
Flow Rate: 45 m³/h.
Max. working pressure: 8 bar; 116 psi.
Connection: 90mmx110mm - flange.

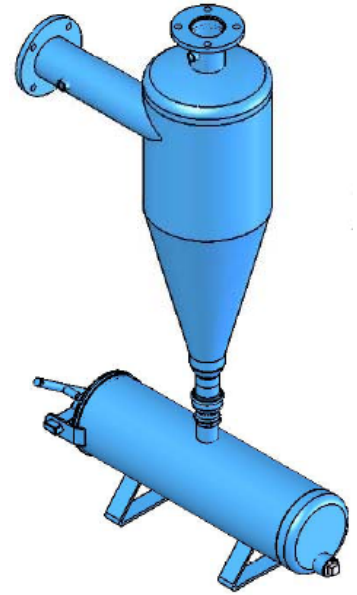

Article No.	Description
482.710.003	Upper gasket
482.710.013	Cover
482.710.022	T-handle
482.710.033	Shutter unit
482.710.044	Steel insert
482.710.054	30 liter chamber

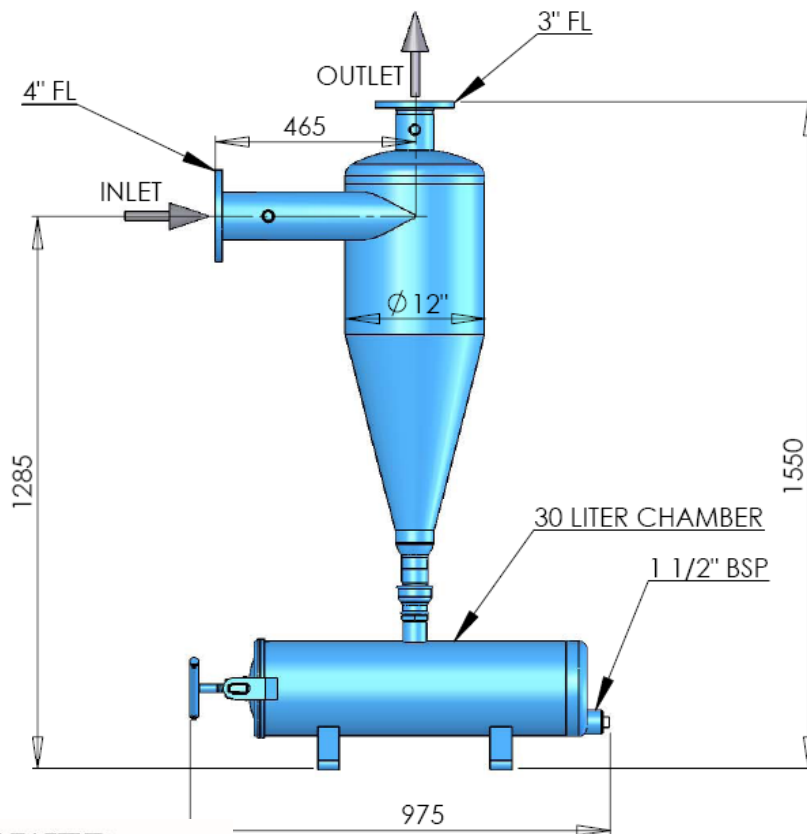

**POWER
PLASTICS b.v.**

More info - - Call +31 252 216650

Power Filter

F760 – sand separator 4.0” – flange

Article number: 482.700.760
Net weight: 94 kg.
Flow Rate: 70 m³/h.
Max. working pressure: 8 bar; 116 psi.
Connection: 110mm - flange.

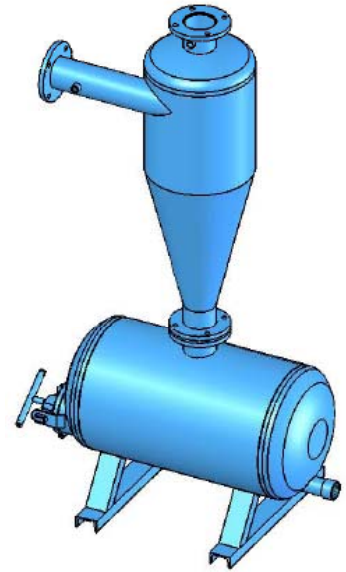

Article No.	Description
482.710.004	Upper gasket
482.710.014	Cover
482.710.022	T-handle
482.710.033	Shutter unit
482.710.045	Rubber insert
482.710.056	150 liter chamber

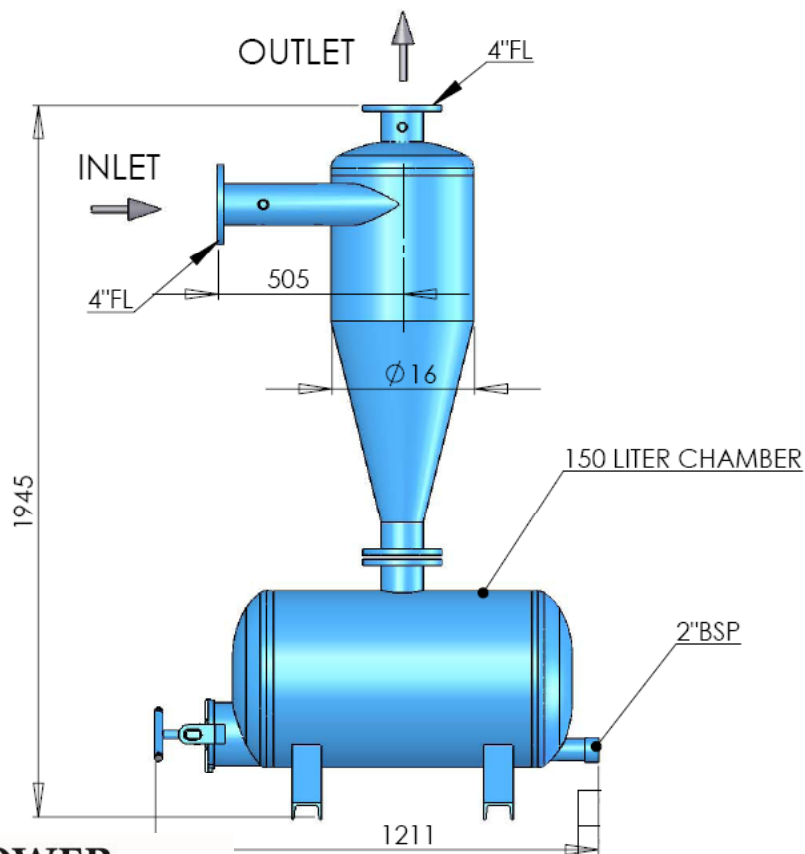

**POWER
PLASTICS b.v.**

More info - - Call +31 252 216650

Power Filter

F770 – sand separator 6.0” – flange

Article number: 482.700.770
Net weight: 225 kg.
Flow Rate: 140 m³/h.
Max. working pressure: 8 bar; 116 psi.
Connection: 160mm - flange.

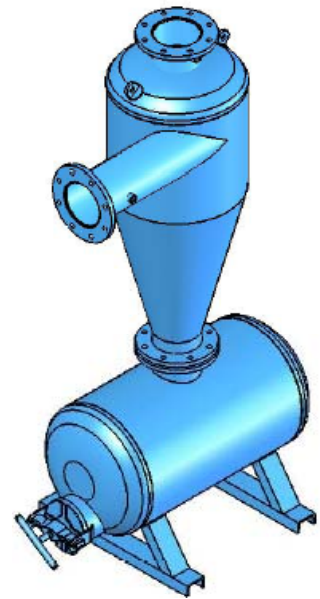

Article No.	Description
482.710.002	Upper gasket
482.710.012	Cover
482.710.022	T-handle
482.710.032	Shutter unit
482.710.046	Rubber insert
482.710.056	150 liter chamber

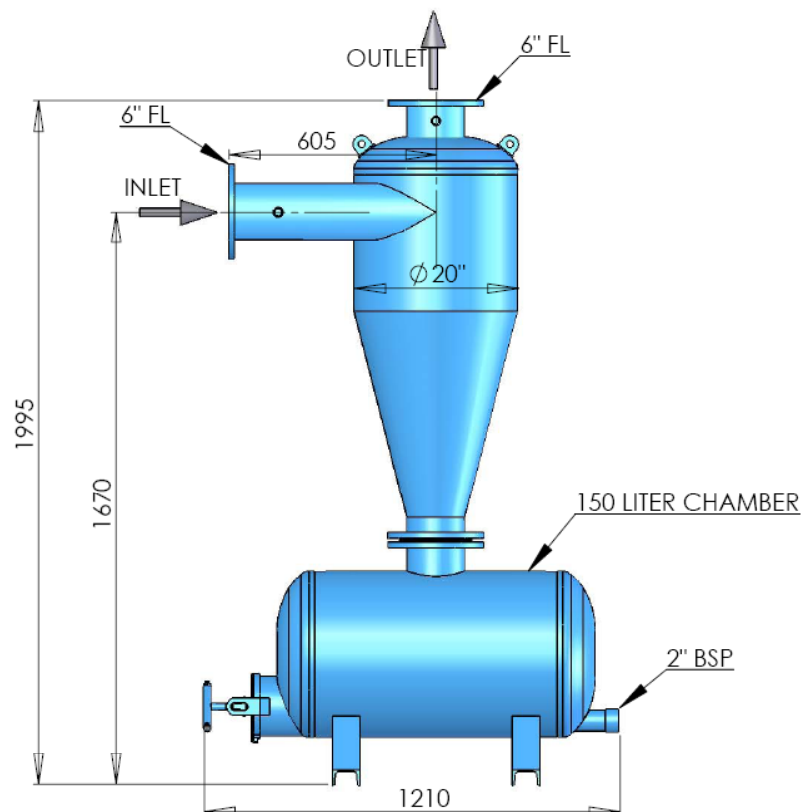

Power Filter



**POWER
PLASTICS b.v.**

More info - - Call +31 252 216650

F775 – sand separator 6.0” – flange

Article number: 482.700.775
Net weight: 270 kg.
Flow Rate: 195 m³/h.
Max. working pressure: 8 bar; 116 psi.
Connection: 160mm - flange.

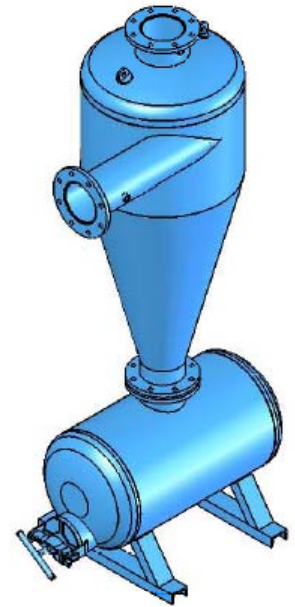

Article No.	Description
482.710.002	Upper gasket
482.710.012	Cover
482.710.022	T-handle
482.710.032	Shutter unit
482.710.046	Rubber insert
482.710.056	150 liter chamber

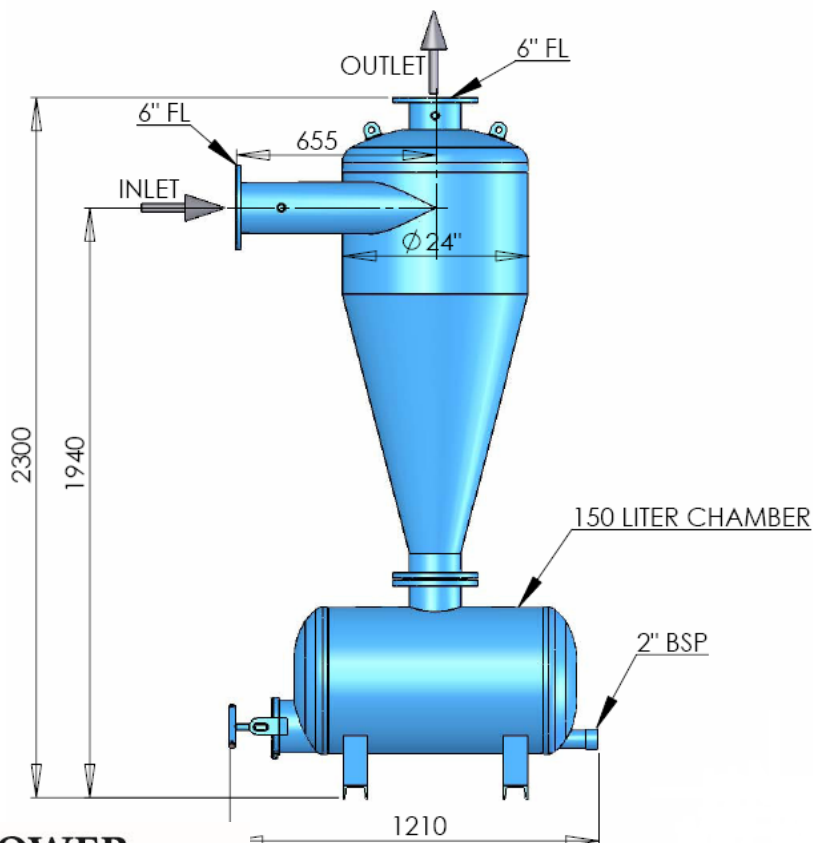

Power Filter



**POWER
 PLASTICS b.v.**

More info - - Call +31 252 216650

F780 – sand separator 8.0” – flange

Article number: 482.700.780
Net weight: 330 kg.
Flow Rate: 300 m³/h.
Max. working pressure: 8 bar; 116 psi.
Connection: 200mm - flange.

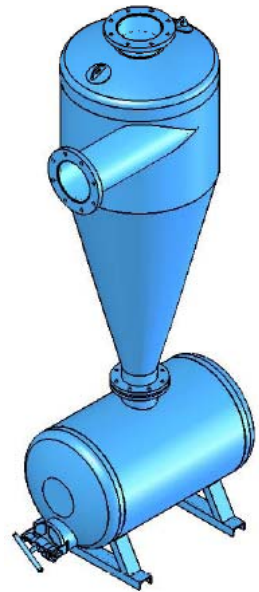

Article No.	Description
482.710.002	Upper gasket
482.710.012	Cover
482.710.022	T-handle
482.710.032	Shutter unit
482.710.046	Rubber insert
482.710.057	300 liter chamber

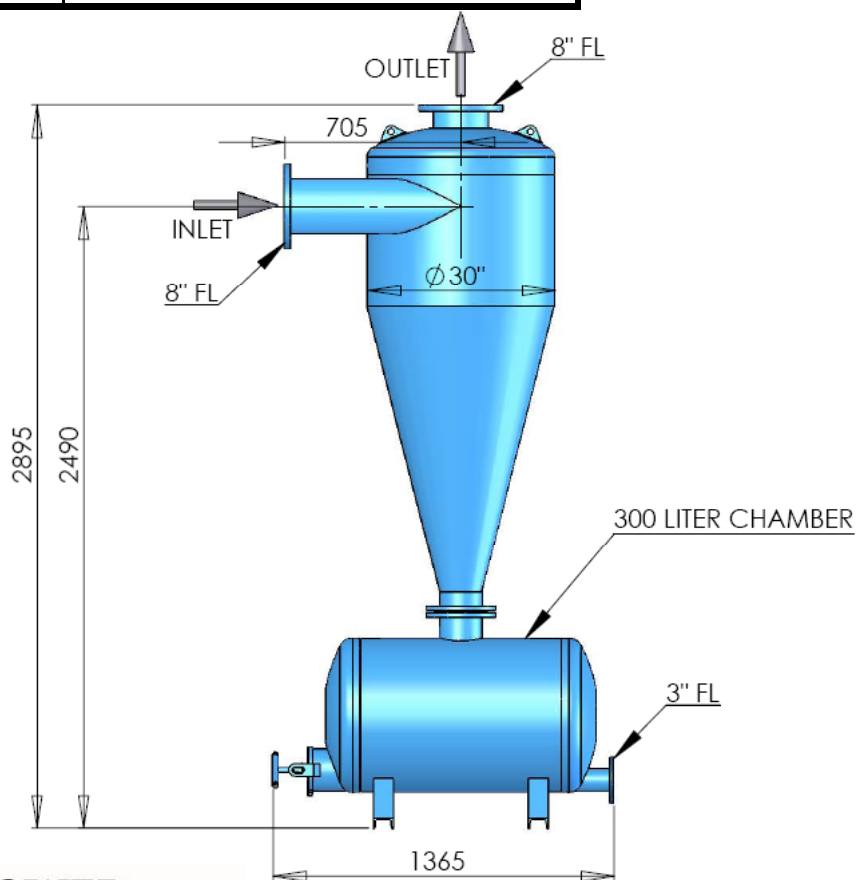

Power Filter



**POWER
 PLASTICS b.v.**

More info - - Call +31 252 216650