



PNEUMATIC ACTUATORS

ACT-850

Index



SPRING RETURN
"ASR"



DOUBLE ACTING
"ADA"

Manufacturing program:



II 2 G D C - LCIE 05 AR 022

Quality & Environmental Management:



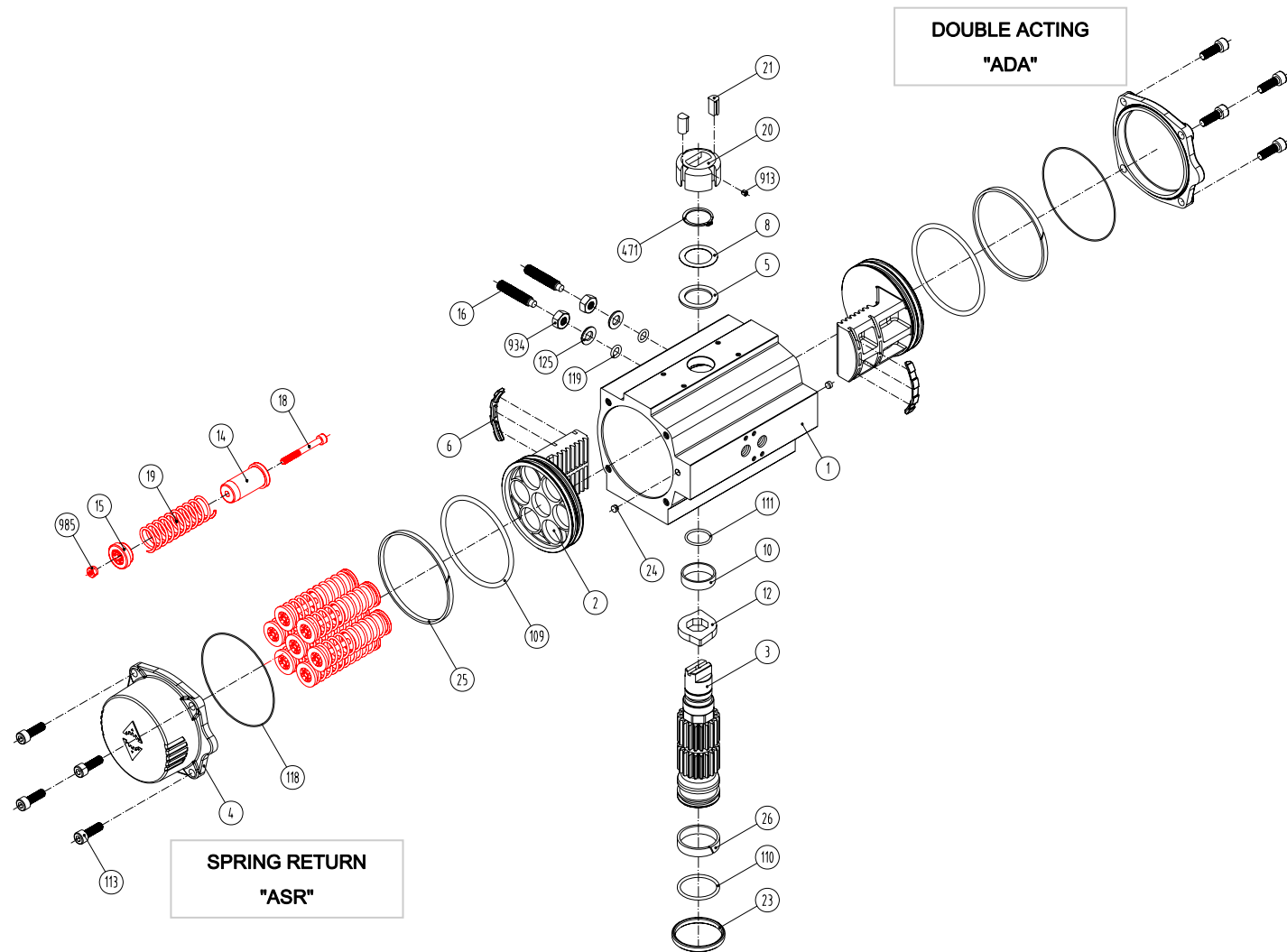

DOUBLE ACTING
"ADA"

SPRING RETURN
"ASR"

Item	Description	Material	Item	Description	Material
1	Body	Aluminium Hard Anodized	23	Centering Ring	Nickel Plated Carbon Steel
2	Piston	Aluminium	24	Plug Air Stop	NBR
3	Pinion	Nickel Plated Carbon Steel	25	Slide Guide	Polyamide PA 6.6 + 30% G.F.
4	End Caps	Aluminium Epoxy Coated	26	Lower Pinion Bearing	Hostalen RCH 1000
5	Soft Pinion Washer	Polyamide PA 6.6	109	O-Ring	NBR
6	Slide Piston	Polyamide PA 6.6 + 30% G.F.	110	O-Ring	NBR
8	Pinion Washer	Stainless Steel	111	O-Ring	NBR
10	Upper Pinion Bearing	Hostalen RCH 1000	113	Bolt	Stainless Steel
12	Stop	ASTMA 105	118	O-Ring	NBR
14	(*) Spring's Long Support	Polyamide PA 6.6	119	O-Ring	NBR
15	(*) Spring's Short Support	Polyamide PA 6.6	125	Washer	Stainless Steel
16	Leveling Screw	Stainless Steel	913	Set Screw	Stainless Steel
18	(*) Bolt	Stainless Steel	471	External Circlip	Stainless Steel
19	(*) Spring	DIN 2076 -D-5.6	934	Nut	Stainless Steel
20	Position Indicator	Polyamide	985	(*) Nut	Stainless Steel
21	Cam	Polyamide			

(*) Only for serie **ASR**

Dimensions

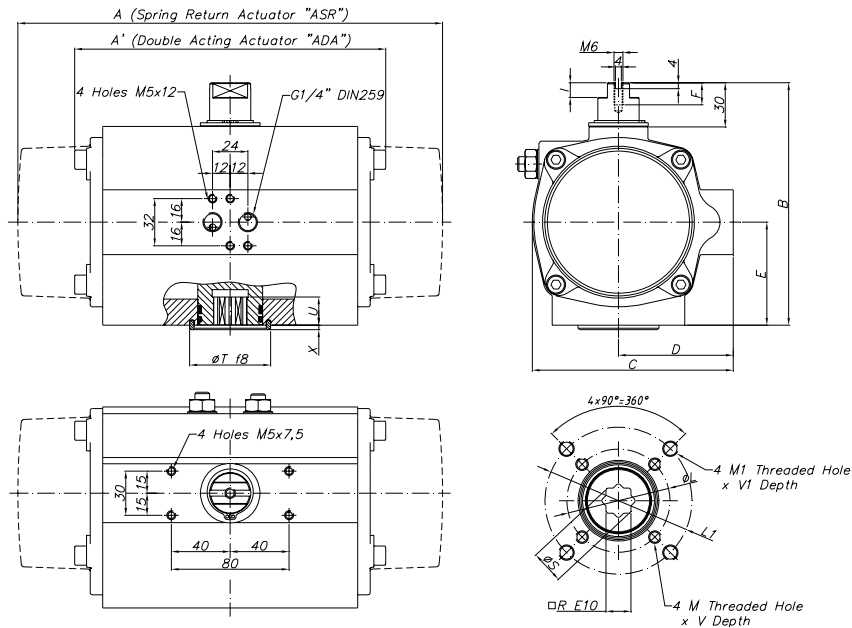

A	A'	B	C	D	E	F	I	R	ØS	ISO 5211	ØL	M x V	ISO 5211	ØL1	M1 x V1	ØT	X	U
473	372	221	191,5	106	98	15	15	27	36,5	F10	102	M10x17	F12	125	M12x20	85	3	40

(*) Dimensions in mm

GENERAL CHARACTERISTICS	Serie ADA	Actuator	Double	Acting
	Serie ASR	Actuator	Spring	Return
DESIGN STANDARDS				
Mounting of solenoid valves	NAMUR Std.			
Mounting of devices	NAMUR VDI		NAMUR VDE 3845 Std.	
Coupling according	ISO 5211		DIN 3337	
Marking	CE		II 2 G D c LCIE 05 AR 022	
TESTS AND CERTIFICATES				
Quality Assurance	ISO 9001			

Max. Pressure	Rotation	Screw stroke Adjustment	Chamber Ø (mm)	Air Volume (L)		Stroke Time (Sec. (A))		Operating Temperature (°C)		
				Opening	Closing	Opening	Closing	STD (standard)	HT (high temp.)	LT (low temp.)
8 bar	90° ±5°	For 1° Need 1/3 Turn	160	4,7	3,86	D 0,8	D 0,9	NBR "O" Ring	FPM "O" Ring	Silicone "O" Ring
						S 2,2	S 2,6	-30° to +100°	-15° to +150°	-40° to +80°

Double Acting Actuator "ADA" Torque Output in Nm

TYPE	Output Torque For Double Acting in Nm										Weight (Kg)										
	3 bar		3,5 bar		4 bar		4,5 bar		5 bar			5,5 bar		6 bar (A)		6,5 bar		7 bar		8 bar	
Pressure	0°	90°	0°	90°	0°	90°	0°	90°	0°	90°	0°	90°	0°	90°	0°	90°	0°	90°	0°	90°	
D	359		419		479		538		598		658		718		778		837		957		16,9

Spring Return Actuator "ASR" Torque Output in Nm

TYPE	Output Torque For Spring Return in Nm																Spring stroke		Weight (Kg)					
	3 bar		3,5 bar		4 bar		4,5 bar		5 bar		5,5 bar		6 bar (A)		6,5 bar		7 bar			8 bar		END	STAR	
Pressure	0°	90°	0°	90°	0°	90°	0°	90°	0°	90°	0°	90°	0°	90°	0°	90°	0°	90°	0°	90°	0°	90°	END	STAR
S06	260	209	320	269	380	328	440	388	500	448	559	508	619	568	679	627	739	687	858	807	116	177	19,7	
S08	227	159	287	218	347	278	407	338	467	398	526	458	586	518	646	577	706	637	826	757	155	236	20,3	
S10			254	168	314	228	374	288	434	348	494	408	553	467	613	527	673	587	793	707	193	295	20,9	
S12						341	238	401	298	461	358	521	417	580	477	640	537	760	657	232	353	21,6		
S14 (A)											428	307	488	367	547	427	607	487	727	607	271	412	22,2	

(A) Standard construction