



PNEUMATIC ACTUATORS

ACT-80

Index



SPRING RETURN
"ASR"



DOUBLE ACTING
"ADA"

Manufacturing program:

Ex II 2 G D c - LCIE 05 AR 022

Quality & Environmental Management:



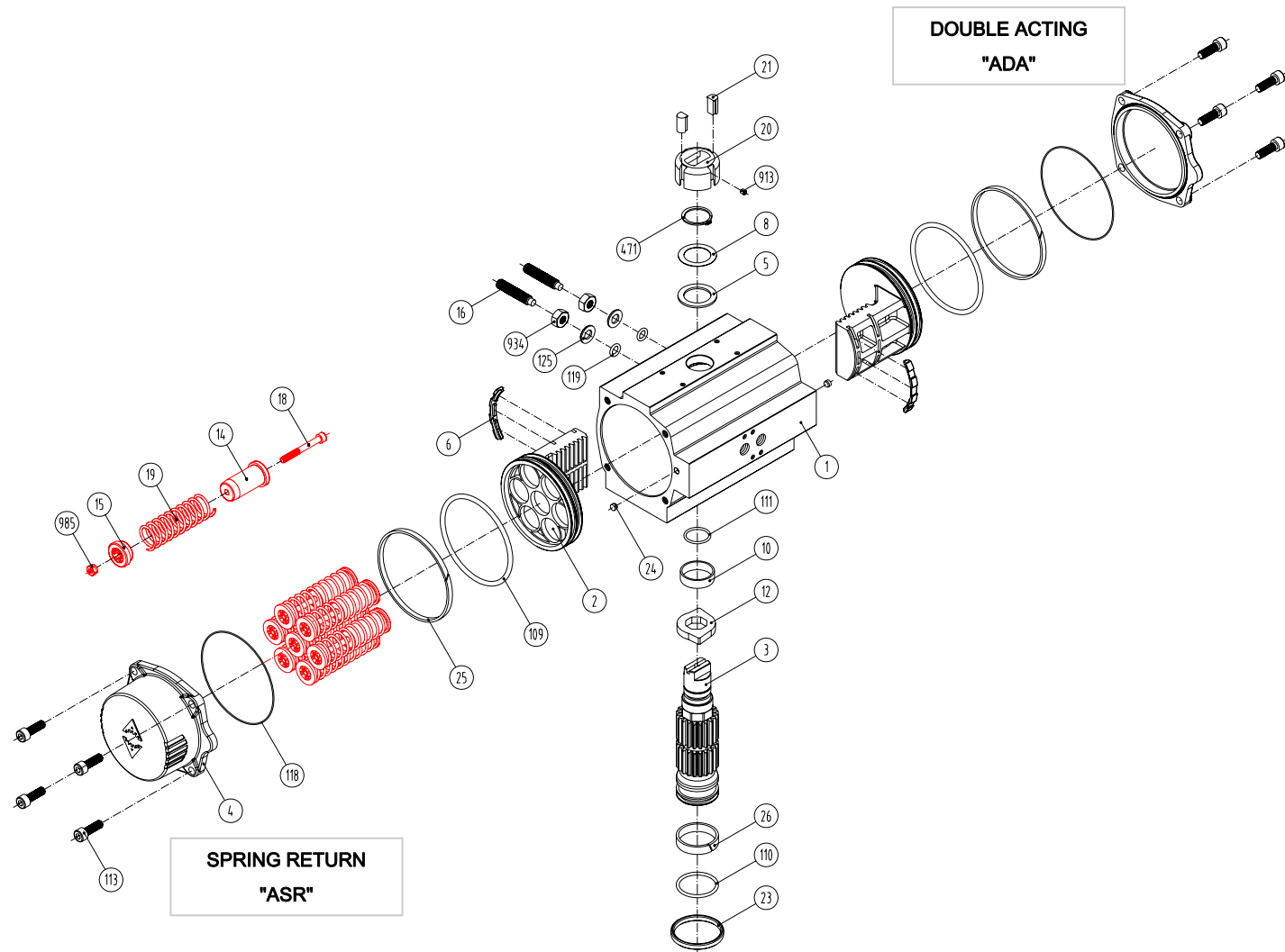

Item	Description	Material	Item	Description	Material
1	Body	Aluminium Hard Anodized	23	Centering Ring	Nickel Plated Carbon Steel
2	Piston	Aluminium	24	Plug Air Stop	NBR
3	Pinion	Nickel Plated Carbon Steel	25	Slide Guide	Polyamide PA 6.6 + 30% G.F.
4	End Caps	Aluminium Epoxy Coated	26	Lower Pinion Bearing	Hostalen RCH 1000
5	Soft Pinion Washer	Polyamide PA 6.6	109	O-Ring	NBR
6	Slide piston	Polyamide PA 6.6 + 30% G.F.	110	O-Ring	NBR
8	Pinion Washer	Stainless Steel	111	O-Ring	NBR
10	Upper Pinion Bearing	Hostalen RCH 1000	113	Bolt	Stainless Steel
12	Stop	ASTMA 105	118	O-Ring	NBR
14	(*) Spring's Long Support	Polyamide PA 6.6	119	O-Ring	NBR
15	(*) Spring's Short Support	Polyamide PA 6.6	125	Washer	Stainless Steel
16	Leveling Screw	Stainless Steel	913	Set Screw	Stainless Steel
18	(*) Bolt	Stainless Steel	471	External Circlip	Stainless Steel
19	(*) Spring	DIN 2076 -D-5.6	934	Nut	Stainless Steel
20	Position Indicator	Polyamide	985	(*) Nut	Stainless Steel
21	Cam	Polyamide			

(*) Only for serie **ASR**

Dimensions

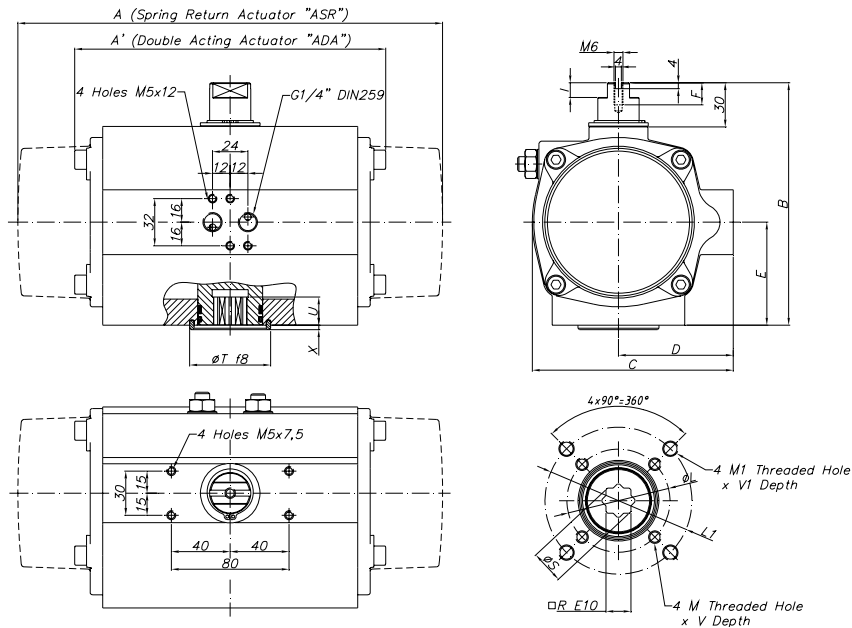

A	A'	B	C	D	E	F	I	R	ØS	ISO	ØL	M x V	ISO	ØL1	M1 x V1	ØT	X	U
218	177	137	111	66	55	12	8	17	22,5	F05	50	M6x10	F07	70	M8x16	55	3	19

(*) Dimensions in mm

GENERAL CHARACTERISTICS	Serie ADA Serie ASR	Actuator Actuator	Double Spring	Acting Return
DESIGN STANDARDS				
Mounting of solenoid valves	NAMUR Std.			
Mounting of devices	NAMUR VDI		NAMUR VDE 3845 Std.	
Coupling according	ISO 5211		DIN 3337	
Marking	⊕II 2 G D c LCIE 05 AR 022			
TESTS AND CERTIFICATES				
Quality Assurance	ISO 9001			

Max. Pressure	Rotation	Screw stroke Adjustment	Chamber Ø (mm)	Air Volume (L)		Stroke Time (Sec. (A))		Operating Temperature (°C)				
				Opening	Closing	Opening	Closing	STD (standard)	HT (high temp.)	LT (low temp.)		
8 bar	90° ±5°	For 1° Need 1/4 Turn	80	0,64	0,47	D	0,11	D	0,10	NBR "O" Ring	FPM "O" Ring	Silicone "O" Ring
						S	0,27	S	0,40	-30° to +100°	-15° to +150°	-40° to +80°

Double Acting Actuator "ADA" Torque Output in Nm

TYPE	Output Torque For Double Acting in Nm										Weight (Kg)										
	3 bar		3,5 bar		4 bar		4,5 bar		5 bar			5,5 bar		6 bar (A)		6,5 bar		7 bar		8 bar	
Pressure	0°	90°	0°	90°	0°	90°	0°	90°	0°	90°	0°	90°	0°	90°	0°	90°	0°	90°	0°	90°	
D	38,5		44,9		51,3		57,7		64,1		70,5		77		83		90		103		3

Spring Return Actuator "ASR" Torque Output in Nm

TYPE	Output Torque For Spring Return in Nm																Spring stroke		Weight (Kg)					
	3 bar		3,5 bar		4 bar		4,5 bar		5 bar		5,5 bar		6 bar (A)		6,5 bar		7 bar			8 bar		END	STAR	
Pressure	0°	90°	0°	90°	0°	90°	0°	90°	0°	90°	0°	90°	0°	90°	0°	90°	0°	90°	0°	90°	0°	90°	0°	90°
S04	31	27	38	34	44	40	50	46	57	53	63	59	70	66	76	72	82	78	95	91	9	13	3,28	
S06	27	21	34	28	40	34	47	41	53	47	59	53	66	60	72	66	79	73	92	86	13	20	3,36	
S08					37	29	43	35	49	41	56	48	62	54	69	61	75	67	88	80	17	27	3,43	
S10							39	29	46	36	52	42	59	49	65	55	71	61	84	74	22	33	3,51	
S12									42	30	48	36	55	43	61	49	68	56	81	69	26	40	3,58	
S14 (A)											45	31	51	37	58	44	64	50	77	63	30	47	3,65	

(A) Standard construction