



PNEUMATIC ACTUATORS

ACT-500

Index



SPRING RETURN
"ASR"



DOUBLE ACTING
"ADA"

Manufacturing program:



II 2 G D C - LCIE 05 AR 022

Quality & Environmental Management:



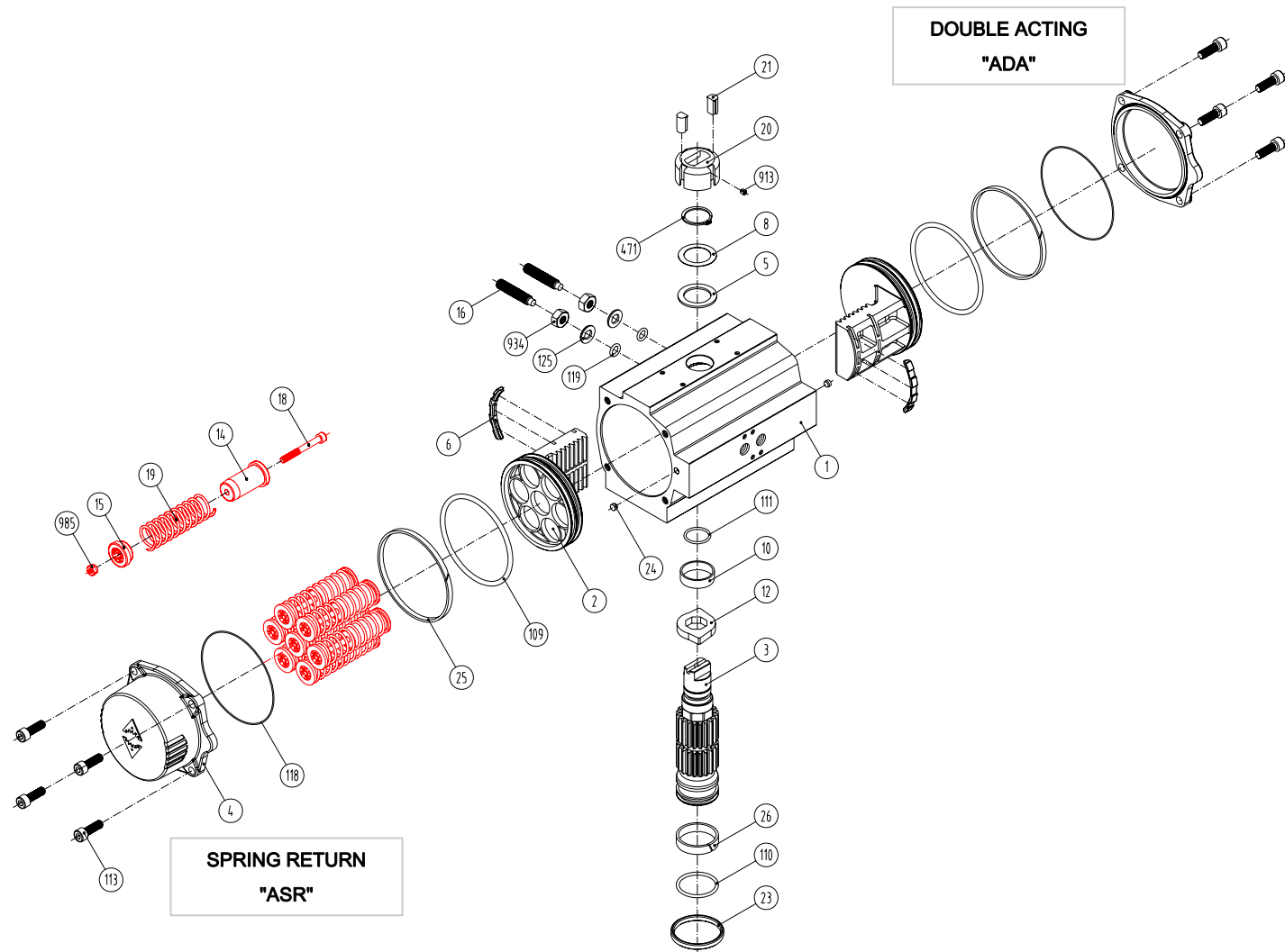

Item	Description	Material	Item	Description	Material
1	Body	Aluminium Hard Anodized	23	Centering Ring	Nickel Plated Carbon Steel
2	Piston	Aluminium	24	Plug Air Stop	NBR
3	Pinion	Nickel Plated Carbon Steel	25	Slide Guide	Polyamide PA 6.6 + 30% G.F.
4	End Caps	Aluminium Epoxy Coated	26	Lower Pinion Bearing	Hostalen RCH 1000
5	Soft Pinion Washer	Polyamide PA 6.6	109	O-Ring	NBR
6	Slide Piston	Polyamide PA 6.6 + 30% G.F.	110	O-Ring	NBR
8	Pinion Washer	Stainless Steel	111	O-Ring	NBR
10	Upper Pinion Bearing	Hostalen RCH 1000	113	Bolt	Stainless Steel
12	Stop	ASTMA 105	118	O-Ring	NBR
14	(*) Spring's Long Support	Polyamide PA 6.6	119	O-Ring	NBR
15	(*) Spring's Short Support	Polyamide PA 6.6	125	Washer	Stainless Steel
16	Leveling Screw	Stainless Steel	913	Set Screw	Stainless Steel
18	(*) Bolt	Stainless Steel	471	External Circlip	Stainless Steel
19	(*) Spring	DIN 2076 -D-5.6	934	Nut	Stainless Steel
20	Position Indicator	Polyamide	985	(*) Nut	Stainless Steel
21	Cam	Polyamide			

(*) Only for serie **ASR**

Dimensions

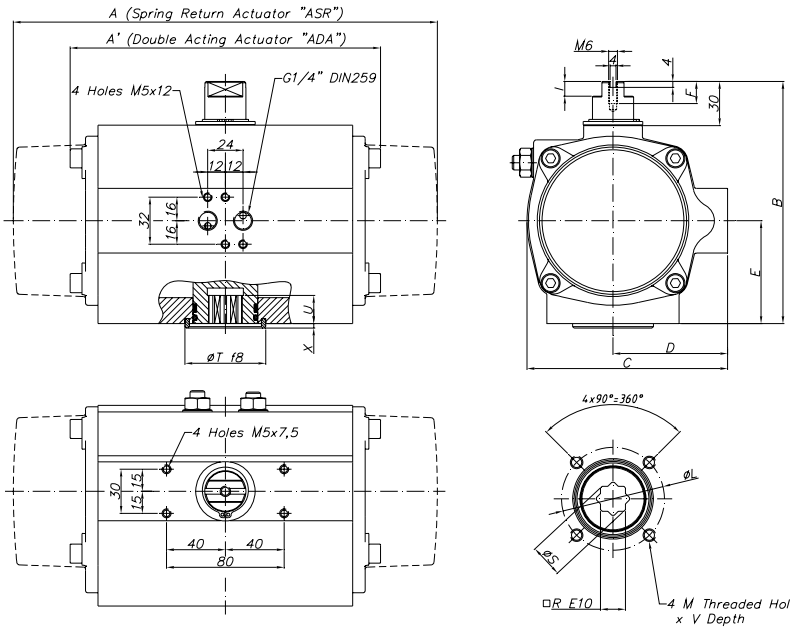

A	A'	B	C	D	E	F	I	R	ØS	ISO	ØL	M x V	ØT	X	U
397	304	199	173	96	85	17	15	22	28,5	F10	102	M10x16	70	3	32

(*) Dimensions in mm

GENERAL CHARACTERISTICS	Serie ADA	Actuator	Double	Acting
	Serie ASR	Actuator	Spring	Return
DESIGN STANDARDS				
Mounting of solenoid valves	NAMUR Std.			
Mounting of devices	NAMUR VDI		NAMUR VDE 3845 Std.	
Coupling according	ISO 5211		DIN 3337	
Marking	CE		II 2 G D c LCIE 05 AR 022	
TESTS AND CERTIFICATES				
Quality Assurance	ISO 9001			

Max. Pressure	Rotation	Screw stroke Adjustment	Chamber Ø (mm)	Air Volume (L)		Stroke Time (Sec. (A))		Operating Temperature (°C)		
				Opening	Closing	Opening	Closing	STD (standard)	HT (high temp.)	LT (low temp.)
								NBR "O" Ring	FPM "O" Ring	Silicone "O" Ring
8 bar	90° ±5°	For 1° Need 1/4 Turn	140,2	2,95	2,74	D 0,4	D 0,5	-30° to +100°	-15° to +150°	-40° to +80°
						S 0,9	S 1,1			

Double Acting Actuator "ADA" Torque Output in Nm

TYPE	Output Torque For Double Acting in Nm										Weight (Kg)											
	3 bar		3,5 bar		4 bar		4,5 bar		5 bar			5,5 bar		6 bar (A)		6,5 bar		7 bar		8 bar		
Pressure	0°	90°	0°	90°	0°	90°	0°	90°	0°	90°	0°	90°	0°	90°	0°	90°	0°	90°	0°	90°	0°	90°
D	217		253		289		325		361		397		433		469		505		577		11,2	

Spring Return Actuator "ASR" Torque Output in Nm

TYPE	Output Torque For Spring Return in Nm																Spring stroke		Weight (Kg)					
	3 bar		3,5 bar		4 bar		4,5 bar		5 bar		5,5 bar		6 bar (A)		6,5 bar		7 bar			8 bar		END	STAR	
Pressure	0°	90°	0°	90°	0°	90°	0°	90°	0°	90°	0°	90°	0°	90°	0°	90°	0°	90°	0°	90°	0°	90°	0°	90°
S06	152	119	188	155	224	191	260	227	296	263	333	299	369	335	405	371	441	407	513	480	76	115	13,33	
S08	131	86	167	122	203	158	239	194	275	231	311	267	347	303	383	339	419	375	492	447	101	153	13,84	
S10					181	126	217	162	254	198	290	234	326	270	362	306	398	342	470	414	126	192	14,35	
S12							196	129	232	165	268	201	304	238	340	274	376	310	449	382	152	230	14,85	
S14 (A)											247	169	283	205	319	241	355	277	427	349	177	268	15,36	

(A) Standard construction