



# PNEUMATIC ACTUATORS

## ACT-300

**Index**



**SPRING RETURN**  
**"ASR"**



**DOUBLE ACTING**  
**"ADA"**

Manufacturing program:

**Ex** II 2 G D c - LCIE 05 AR 022

Quality & Environmental Management:



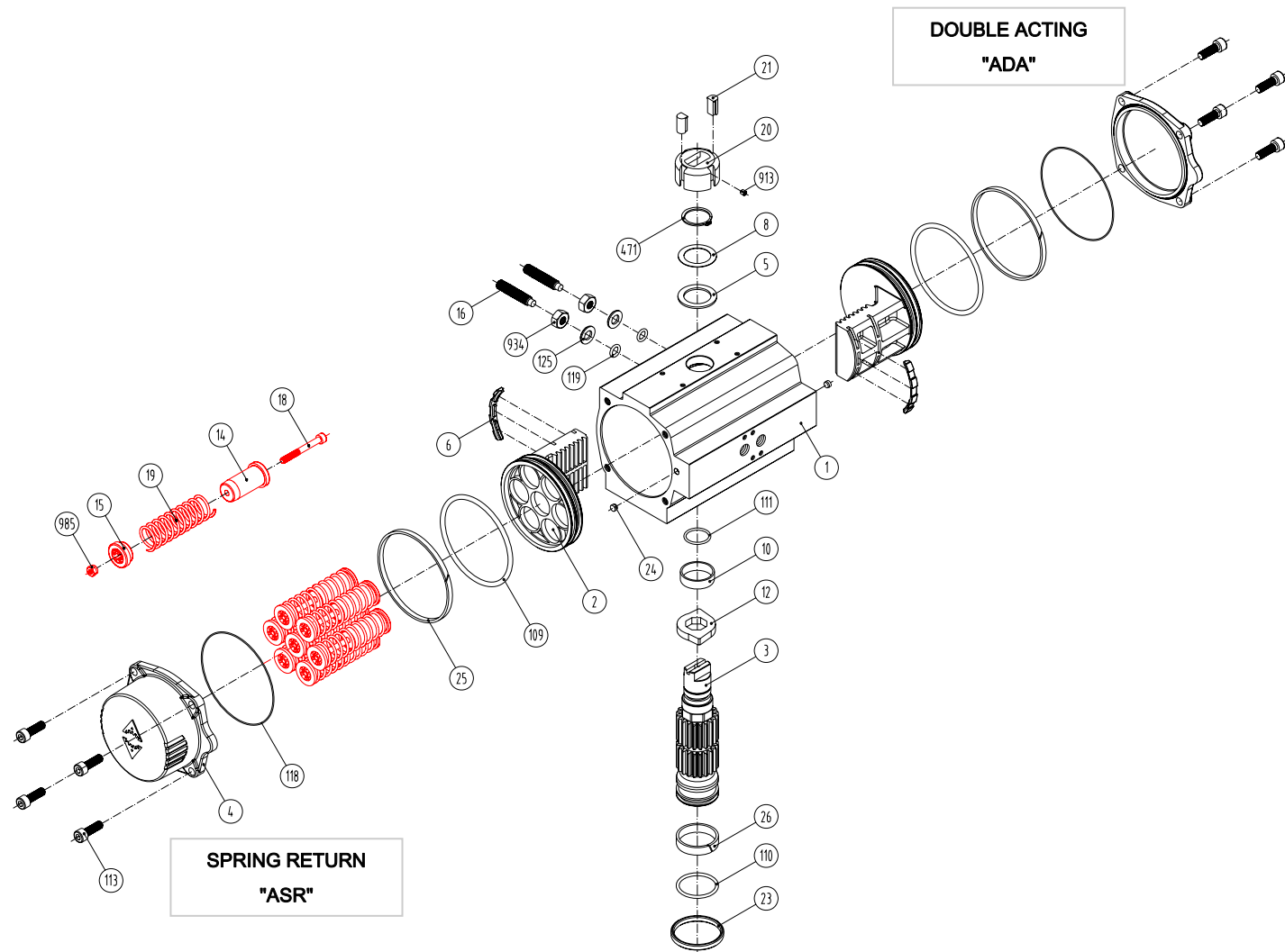

Item	Description	Material	Item	Description	Material
1	Body	Aluminium Hard Anodized	23	Centering Ring	Nickel Plated Carbon Steel
2	Piston	Aluminium	24	Plug Air Stop	NBR
3	Pinion	Nickel Plated Carbon Steel	25	Slide Guide	Polyamide PA 6.6 + 30% G.F.
4	End Caps	Aluminium Epoxy Coated	26	Lower Pinion Bearing	Hostalen RCH 1000
5	Soft Pinion Washer	Polyamide PA 6.6	109	O-Ring	NBR
6	Slide Piston	Polyamide PA 6.6 + 30% G.F.	110	O-Ring	NBR
8	Pinion Washer	Stainless Steel	111	O-Ring	NBR
10	Upper Pinion Bearing	Hostalen RCH 1000	113	Bolt	Stainless Steel
12	Stop	ASTMA 105	118	O-Ring	NBR
14	(*) Spring's Long Support	Polyamide PA 6.6	119	O-Ring	NBR
15	(*) Spring's Short Support	Polyamide PA 6.6	125	Washer	Stainless Steel
16	Leveling Screw	Stainless Steel	913	Set Screw	Stainless Steel
18	(*) Bolt	Stainless Steel	471	External Circlip	Stainless Steel
19	(*) Spring	DIN 2076 -D-5.6	934	Nut	Stainless Steel
20	Position Indicator	Polyamide	985	(*) Nut	Stainless Steel
21	Cam	Polyamide			

(\*) Only for serie **ASR**

### Dimensions

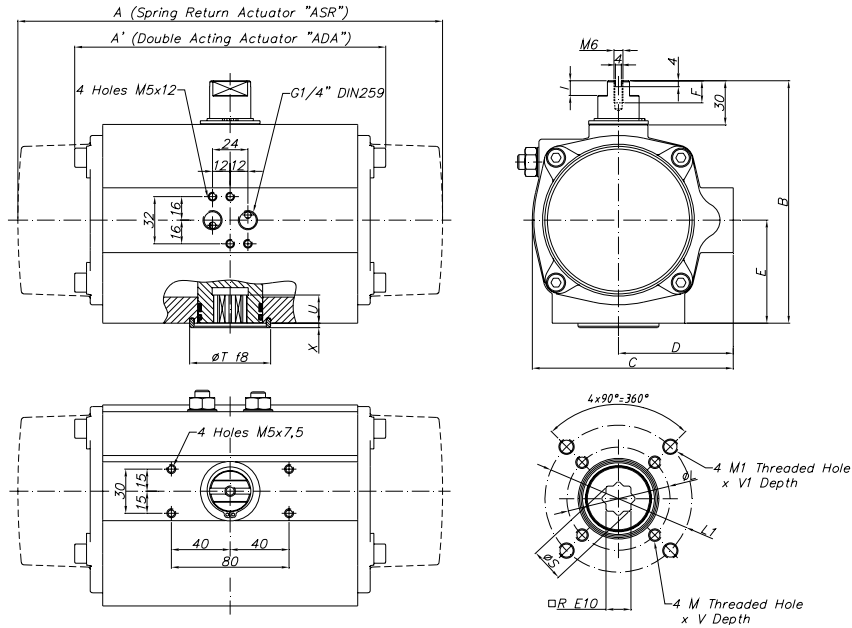

A	A'	B	C	D	E	F	I	R	ØS	ISO	ØL	M x V	ISO	ØL1	M1 x V1	ØT	X	U
348,5	273	182	152,5	86	80	16	12	22	28,5	F07	70	M8x14	F10	102	M10x20	70	3	29

(\*) Dimensions in mm

GENERAL CHARACTERISTICS	Serie <b>ADA</b>	<b>Actuator</b>	<b>Double</b>	<b>Acting</b>
	Serie <b>ASR</b>	<b>Actuator</b>	<b>Spring</b>	<b>Return</b>
DESIGN STANDARDS				
Mounting of solenoid valves	NAMUR Std.			
Mounting of devices	NAMUR VDI	NAMUR VDE 3845 Std.		
Coupling according	ISO 5211	DIN 3337		
Marking	⊗ II 2 G D c LCIE 05 AR 022			
TESTS AND CERTIFICATES				
Quality Assurance	ISO 9001			

Max. Pressure	Rotation	Screw stroke Adjustment	Chamber Ø (mm)	Air Volume (L)		Stroke Time (Sec. (A))		Operating Temperature (°C)		
				Opening	Closing	Opening	Closing	STD (standard)	HT (high temp.)	LT (low temp.)
8 bar	90° ±5°	For 1° Need 1/3 Turn	120,5	1,96	1,73	D 0,3	D 0,4	NBR "O" Ring	FPM "O" Ring	Silicone "O" Ring
						S 0,7	S 0,85	-30° to +100°	-15° to +150°	-40° to +80°

### Double Acting Actuator Torque Output in Nm

TYPE	Output Torque For Double Acting in Nm										Weight (Kg)											
	3 bar		3,5 bar		4 bar		4,5 bar		5 bar			5,5 bar		6 bar (A)		6,5 bar		7 bar		8 bar		
Pressure	0°	90°	0°	90°	0°	90°	0°	90°	0°	90°	0°	90°	0°	90°	0°	90°	0°	90°	0°	90°	0°	90°
D	145		170		194		218		242		267		291		315		339		388		8,5	

### Spring Return Actuator Torque Output in Nm

TYPE	Output Torque For Spring Return in Nm																Spring stroke		Weight (Kg)					
	3 bar		3,5 bar		4 bar		4,5 bar		5 bar		5,5 bar		6 bar (A)		6,5 bar		7 bar			8 bar		END	STAR	
Pressure	0°	90°	0°	90°	0°	90°	0°	90°	0°	90°	0°	90°	0°	90°	0°	90°	0°	90°	0°	90°	0°	90°	0°	90°
S06	102	75	126	99	151	123	175	148	199	172	223	196	247	220	272	245	296	269	344	317	51	83	9,65	
S08			112	76	136	100	160	124	185	148	209	173	233	197	257	221	281	245	330	294	68	111	9,92	
S10					122	76	146	101	170	125	194	149	219	173	243	198	267	222	315	270	85	138	10,20	
S12							131	77	156	101	180	126	204	150	228	174	253	198	301	247	102	166	10,50	
S14 (A)											165	102	190	126	214	151	238	175	287	223	119	193	10,80	

(A) Standard construction