

# F6000 – serie hoogbed zand filters

## Kenmerken:

Verticale tank met filterbodem.

## Toepassingen:

Irrigatie

Recirculatie

Voorfiltratie

Materiaal : 150 mu Epoxy gecoat staal

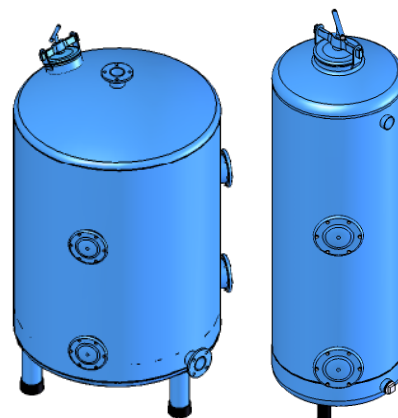

Code	Type	Inch	Diam mm	aansl.	Cm2	Prijs
482 601 020	F6020	20	500	2 inch	2000	2014,85
482 601 025	F6025	25	600	2 inch	2900	2277,50
482 601 030	F6030	30	750	90mm flens	4500	4352,00
482 601 036	F6036	36	900	90mm flens	6550	4641,41
482 601 042	F6042	42	1050	90 mm flens	8800	6377,60
482 601 048	F6048	48	1200	110 mm flens	11700	7081,34

## Technische specificaties:

Toelaatbare werkdruk : 8 bar

Verschil werkdruk : 0,5 bar

Maximale druk : 10 bar

Maximale verschilddruk: : 1 bar

Type coating : Polyester (epoxy) elektrostatich aangebracht

## Werking:

Voorgefilterd water wordt bovenin het zandfilter geleid waarna het water door het zandbed of ander medium wordt geperst. Het aanwezige vuil blijft achter in de poriën van het filterbed. Om dit vuil te verwijderen wordt de stroomrichting omgedraaid waardoor het filterbed expandeert en vuil samen met het spoelwater het filter aan de bovenzijde verlaat naar een afvoer.

## Voordelen:

Groot filteroppervlak - Geen bewegende delen - Diepte filtratie - Eenvoudige werking.

Power Filters



**POWER  
PLASTICS b.v.**

*More info: Call +31 252 216650*

# F6020-HM (80cm media) 20" – thread

**Article number:** 482.601.020  
**Net weight:** 95 kg.  
**Sand:** 320 kg.  
**Flow Rate at 15 m/h:** 3 m<sup>3</sup>/h.  
**Min. back flushing flow rate:** 8 m<sup>3</sup>/h.  
**Max. working pressure:** 8 bar; 116 psi.  
**Connection:** 2.0" - thread.  
**Filtration area:** 2.000 cm<sup>2</sup>.



Article No.	Description
483.660.116	Cover
483.660.117	Gasket for cover
483.660.118	T-handle
483.660.119	Shutter unit
483.660.120	Service cover
483.660.121	Gasket for service cover
482.680.050	Filter nozzle P1 - 500 micron
482.680.055	Rubber bushing for filter nozzle P1

Power Filters

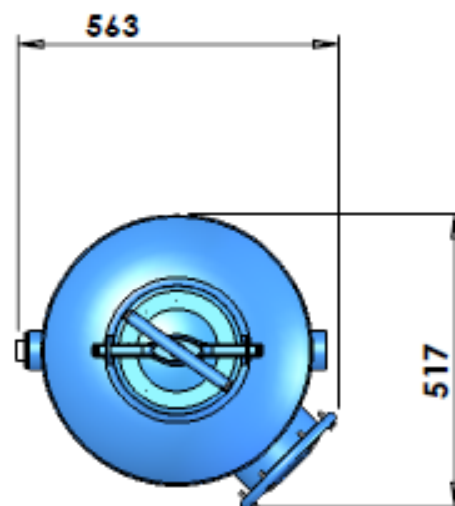
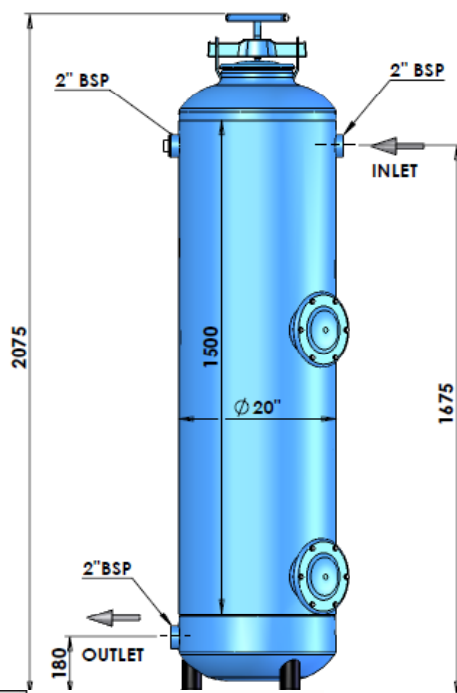

**POWER  
PLASTICS b.v.**

*More info: Call +31 252 216650*

# F6025-HM (80cm media) 25" – thread

**Article number:** 482.601.025  
**Net weight:** 145 kg.  
**Sand:** 480 kg.  
**Flow Rate at 15 m/h:** 5 m<sup>3</sup>/h.  
**Min. back flushing flow rate:** 12 m<sup>3</sup>/h.  
**Max. working pressure:** 8 bar; 116 psi.  
**Connection:** 2.0" - thread.  
**Filtration area:** 3.150 cm<sup>2</sup>.

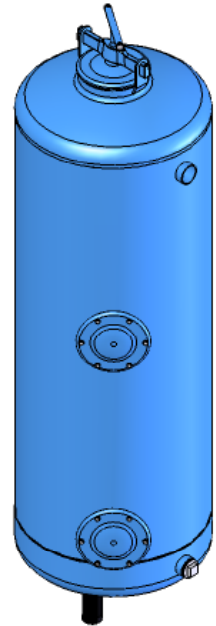

Article No.	Description
483.660.116	Cover
483.660.117	Gasket for cover
483.660.118	T-handle
483.660.119	Shutter unit
483.660.120	Service cover
483.660.121	Gasket for service cover
482.680.050	Filter nozzle P1 - 500 micron
482.680.055	Rubber bushing for filter nozzle P1

Power Filters

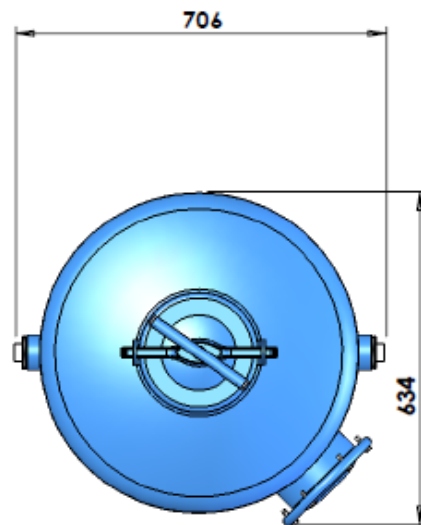
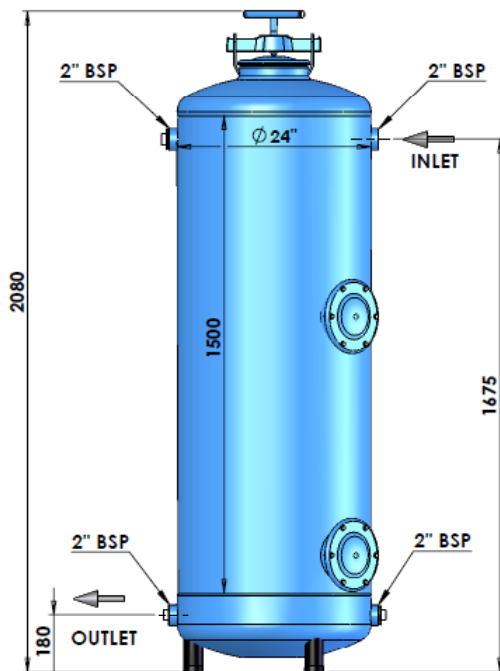

**POWER  
PLASTICS b.v.**

*More info: Call +31 252 216650*

# F6030-HM (80cm media) 30" – thread

**Article number:** 482.601.030  
**Net weight:** 215 kg.  
**Sand:** 720 kg.  
**Flow Rate at 15 m/h:** 7 m<sup>3</sup>/h.  
**Min. back flushing flow rate:** 18 m<sup>3</sup>/h.  
**Max. working pressure:** 8 bar; 116 psi.  
**Connection:** 2.0" - thread.  
**Filtration area:** 4.550 cm<sup>2</sup>.

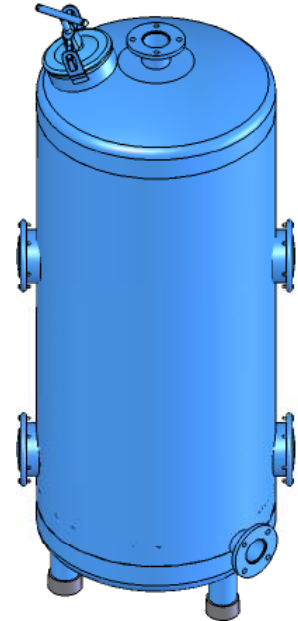

Article No.	Description
483.660.116	Cover
483.660.117	Gasket for cover
483.660.118	T-handle
483.660.119	Shutter unit
483.660.120	Service cover
483.660.121	Gasket for service cover
482.680.050	Filter nozzle P1 - 500 micron
482.680.055	Rubber bushing for filter nozzle P1

Power Filters

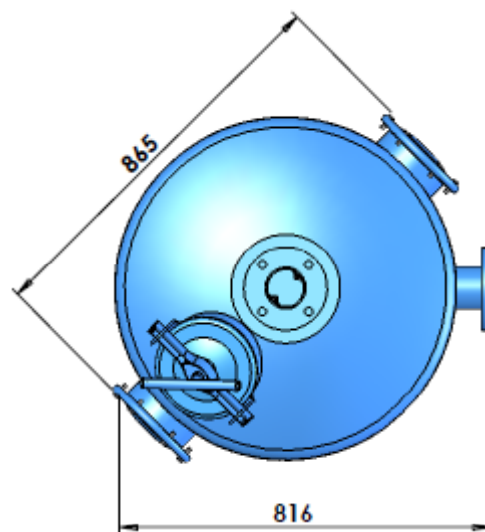
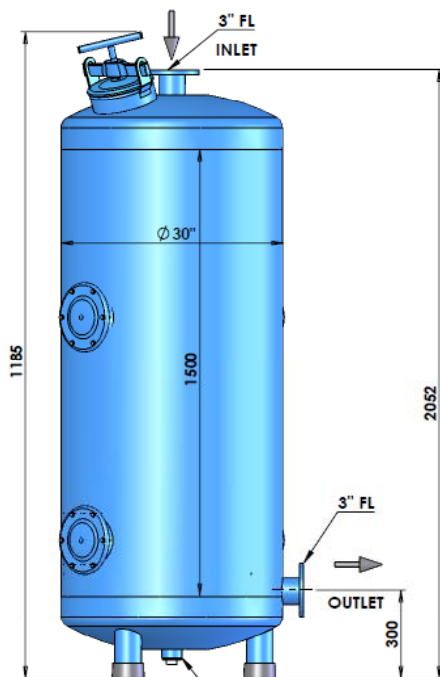

**POWER  
PLASTICS b.v.**

*More info: Call +31 252 216650*

# F6036-HM (80cm media) 36" – thread

**Article number:** 482.601.036  
**Net weight:** 250 kg.  
**Sand:** 1010 kg.  
**Flow Rate at 15 m/h:** 10 m<sup>3</sup>/h.  
**Min. back flushing flow rate:** 27 m<sup>3</sup>/h.  
**Max. working pressure:** 8 bar; 116 psi.  
**Connection:** 2.0" - thread.  
**Filtration area:** 6.550 cm<sup>2</sup>.

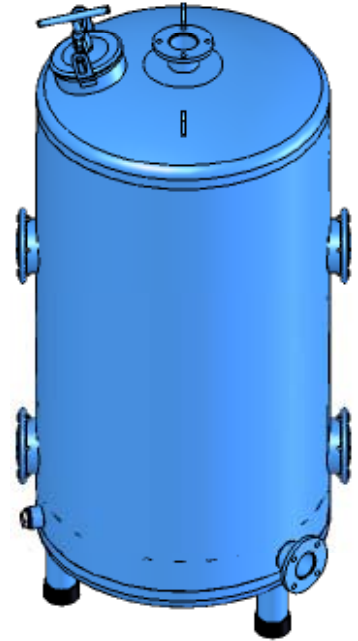

Article No.	Description
483.660.116	Cover
483.660.117	Gasket for cover
483.660.118	T-handle
483.660.119	Shutter unit
483.660.120	Service cover
483.660.121	Gasket for service cover
482.680.050	Filter nozzle P1 - 500 micron
482.680.055	Rubber bushing for filter nozzle P1

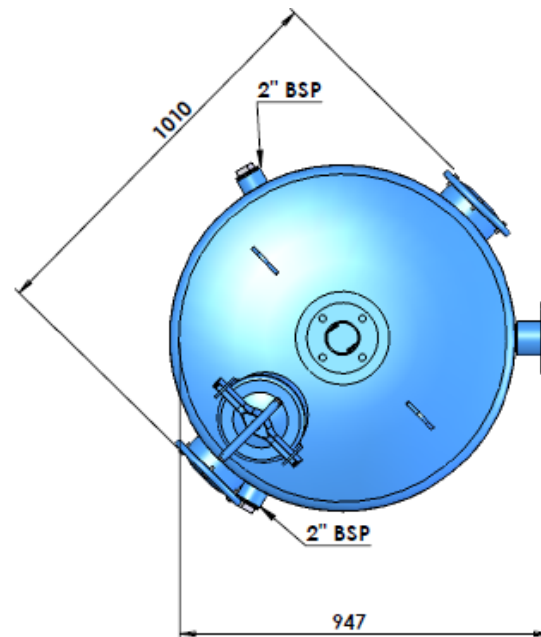
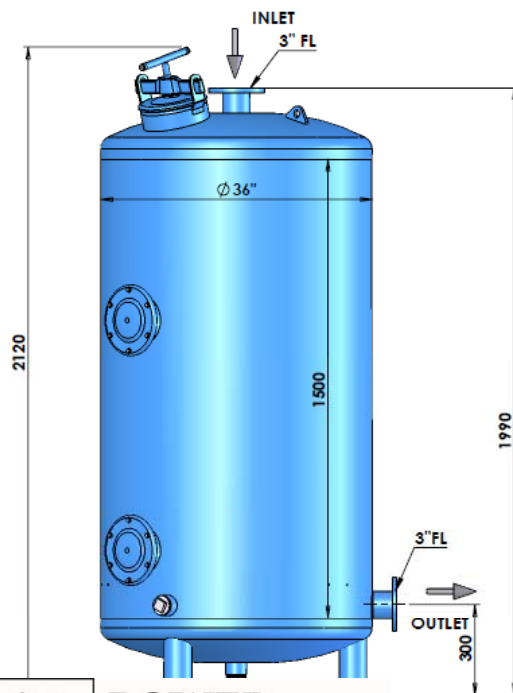

**POWER  
PLASTICS b.v.**

*More info: Call +31 252 216650*

Power Filters

# F6042-HM (80cm media) 42" – thread

**Article number:** 482.601.042  
**Net weight:** 300 kg.  
**Sand:** 1430 kg.  
**Flow Rate at 15 m/h:** 13 m<sup>3</sup>/h.  
**Min. back flushing flow rate:** 36 m<sup>3</sup>/h.  
**Max. working pressure:** 8 bar; 116 psi.  
**Connection:** 2.0" - thread.  
**Filtration area:** 8.650 cm<sup>2</sup>.

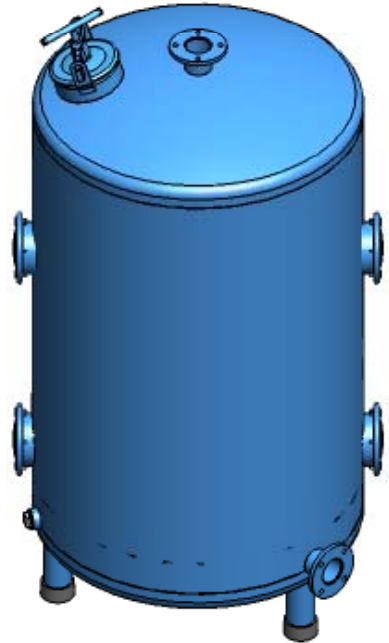

Article No.	Description
483.660.116	Cover
483.660.117	Gasket for cover
483.660.118	T-handle
483.660.119	Shutter unit
483.660.120	Service cover
483.660.121	Gasket for service cover
482.680.050	Filter nozzle P1 - 500 micron
482.680.055	Rubber bushing for filter nozzle P1

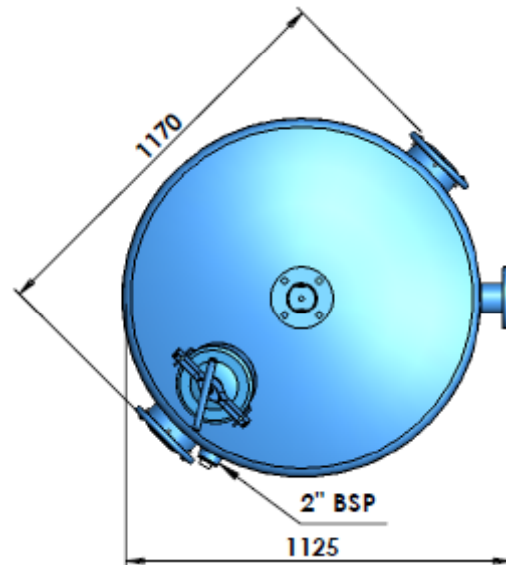
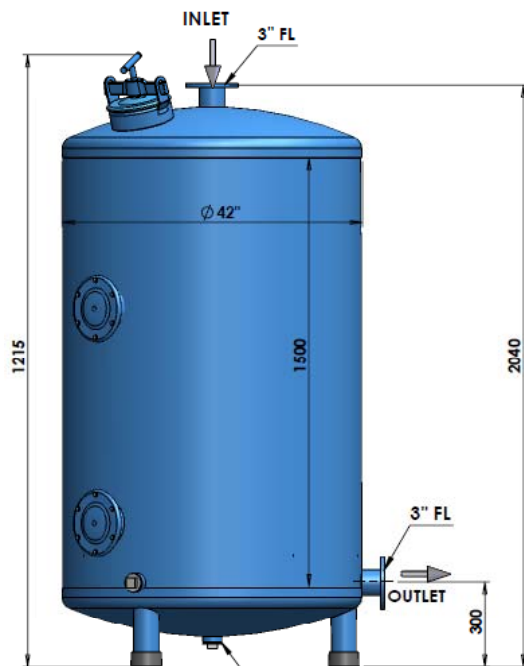

**POWER  
 PLASTICS b.v.**

*More info: Call +31 252 216650*

Power Filters

# F6048-HM (80cm media) 48" – thread

**Article number:** 482.601.048  
**Net weight:** 380 kg.  
**Sand:** 1810 kg.  
**Flow Rate at 15 m/h:** 17 m<sup>3</sup>/h.  
**Min. back flushing flow rate:** 47 m<sup>3</sup>/h.  
**Max. working pressure:** 8 bar; 116 psi.  
**Connection:** 2.0" - thread.  
**Filtration area:** 11.300 cm<sup>2</sup>.

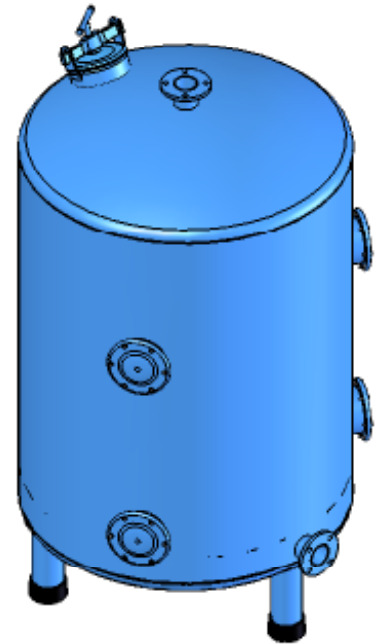

Article No.	Description
483.660.116	Cover
483.660.117	Gasket for cover
483.660.118	T-handle
483.660.119	Shutter unit
483.660.120	Service cover
483.660.121	Gasket for service cover
482.680.050	Filter nozzle P1 - 500 micron
482.680.055	Rubber bushing for filter nozzle P1

Power Filters

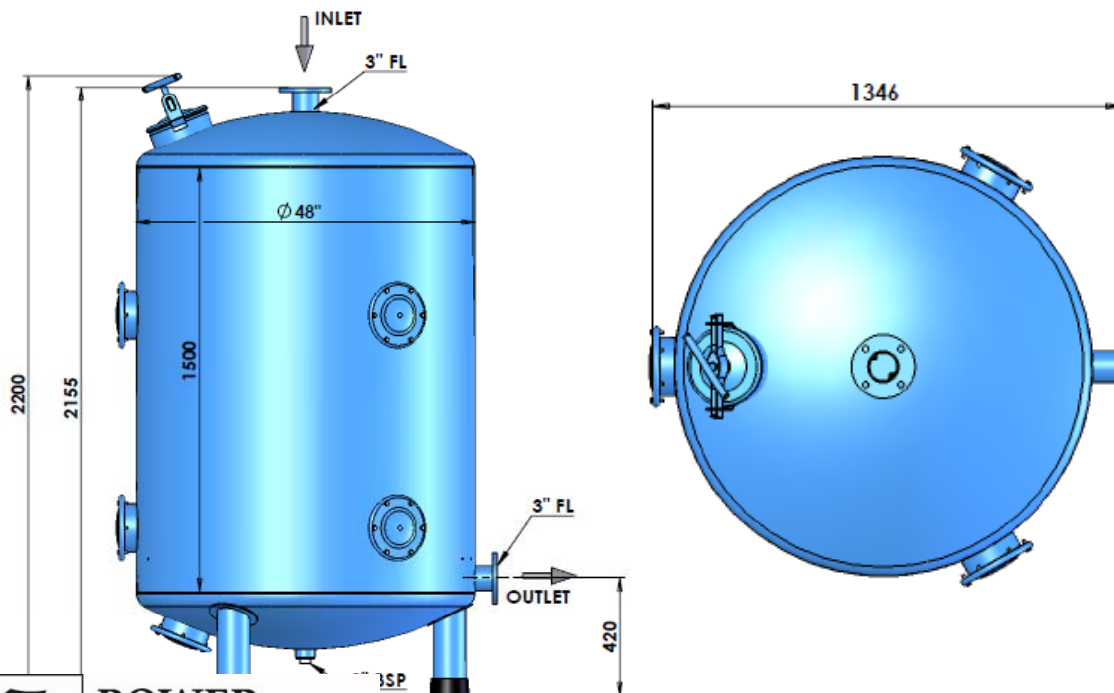

**POWER  
PLASTICS b.v.**

*More info: Call +31 252 216650*

# Parts list – F6000

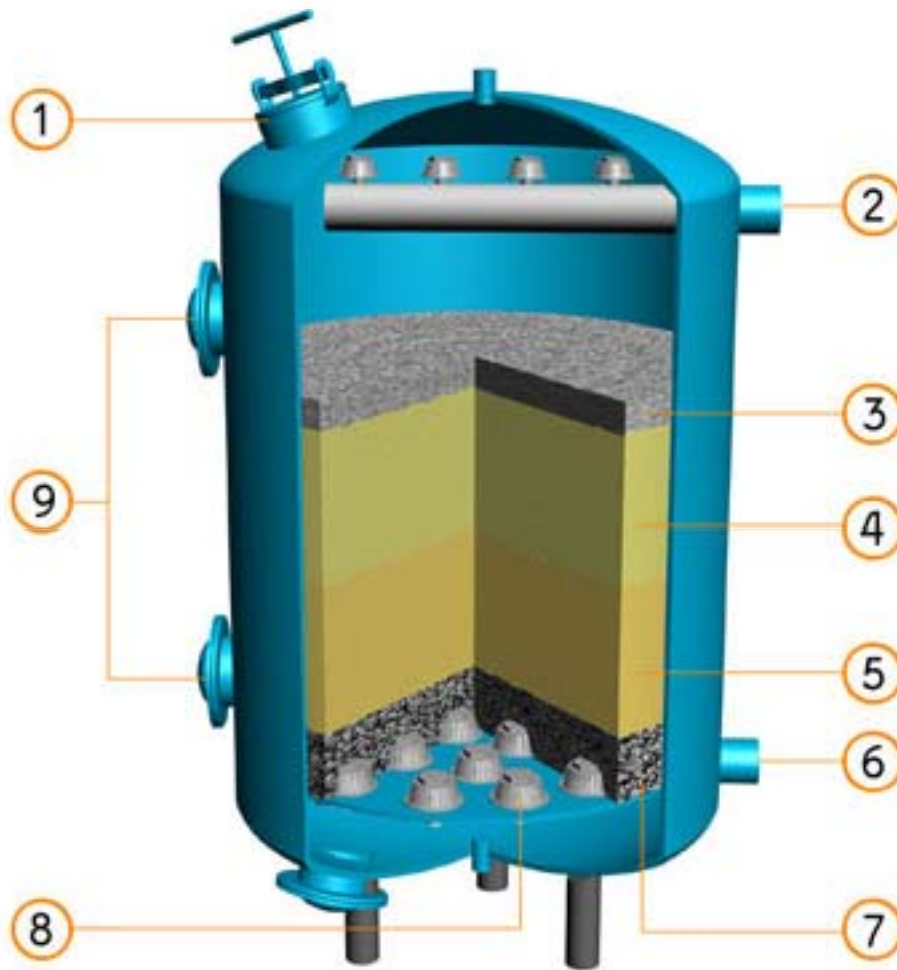

Power Filters

1	Cover + T-handle + Shutter unit
2	Inlet
3	Anthracite layer
4	Fine sand layer
5	Coarse sand layer
6	Outlet
7	Gravel support Layer
8	Filter nozzle P1 - 500 micron
9	Service cover



**POWER  
PLASTICS b.v.**

*More info: Call +31 252 216650*